

NC1151

On-Board Inert Gas Generating System (OBIGGS)

COBHAM

P/N: 3261151

The most important thing we build is trust

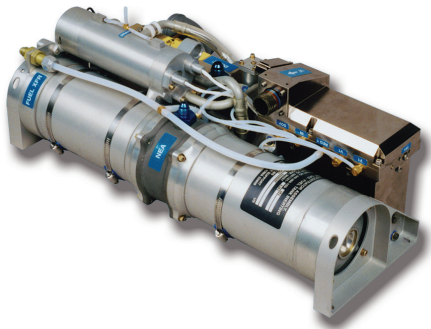

Risk

Combustion of oxygen rich fuel vapors in the fuel tank ullage, leading to explosion and fire. The risk is increased in helicopters due to sloshing of fuel, fuel tank vibration, and inherent vulnerability to enemy ground fire.

Solution

OBIGGS increases aircraft survivability and crew member safety by inerting the aircraft fuel system against ballistic threats up to and including 23mm HEI (High Explosive Incendiary) rounds and environmental threats

such as lightning and static discharge. OBIGGS inertes the aircraft fuel system by providing a continuous flow of generated nitrogen enriched gas into the fuel tanks and thus eliminates the combustible fuel/air ullage mixture.

Adaptability

This OBIGGS is being produced for the AH-1Z Cobra, UH-1Y Huey, and MH-60K Black Hawk helicopters and is designed to accommodate your specific attack, utility and reconnaissance helicopter inerting and fuel system ballistic tolerance requirements.

Features

- Built-in test capability
- Integral heat exchanger, inlet air filter, system controller and oxygen monitor
- Quality product gas is produced immediately on start-up
- Compared to foam, assures increased usable fuel and easy access to fuel tanks by ground crews
- Maintenance and life cycle costs are both significantly lower than other inerting alternatives
- Requires no ground support equipment

Specifications

Operating temperature: -54C to 52C
Weight: 13.25 lbs (6.01 kg) max
Dimensions: 10.6 x 5.8 x 17.1 in
(26.9 x 14.7 x 43.3 cm)
Air consumption: 0.6 lb/min @ 40 psig
Electrical power requirement: 115 VAC / 400 Hz, 70 VA
28 VDC, 14 W

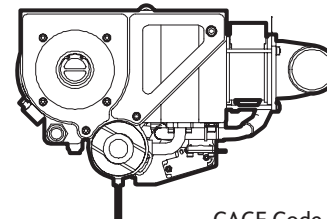
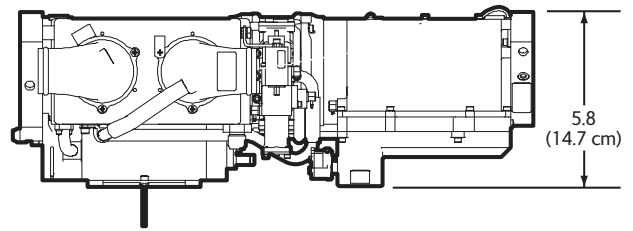
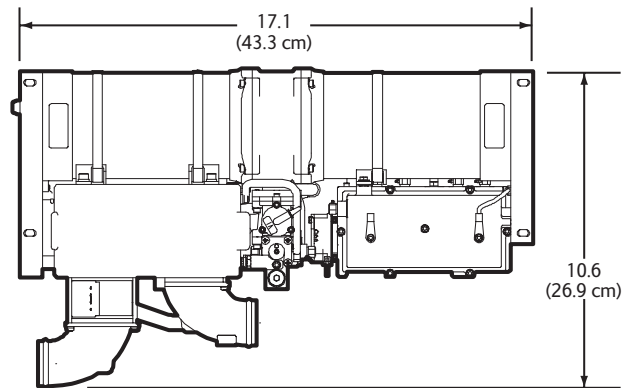

CAGE Code 99251

For further information please contact:

Cobham Life Support
2734 Hickory Grove Road
Davenport, IA 52804 USA

Tel: +1 (563) 383 6000
Fax: +1 (563) 383 6323