

BSU-7100

Beam Steering Unit

COBHAM

Data Sheet

The most important thing we build is trust

Description

The Beam Steering Unit (BSU) is the primary interface between any non-proprietary Satellite Data Unit (SDU) and a modem driven High Gain Antenna. Essentially it acts as a converter from the ARINC 741 SDU's ARINC 429 Protocol to the proprietary protocol used by some Cobham High Gain Inmarsat Antennas. The BSU interfaces to the antenna via a single RF cable carrying power, modem control and GPS RF from the antenna to the satcom system. The BSU has an integrated GPS Engine to provide necessary information to an ARINC 741 SDU.

Features

- ARINC 741 to Cobham proprietary interface converter
- LEDs for simple status display
- Built-in 12-channel GPS Engine
- Added flexibility to a Satcom system
- BITE Functionality via RS-232 to PC or via ARINC 429 to SDU
- Simple installation software

Technical Specifications

Dimensions

Length : 192 mm (7.56")
Width : 162 mm (6.38")
Height : 49.5 mm (1.95")
Weight : 1.5 kg (3.3 lbs)

Interfaces

All digital: Multi-pin (MS3112E20-41P)
Power
ARINC 429
Diagnostics
28 Vdc @ 1.8 Amps
GPS RF: TNC Female
GPS Output from HGA
HGA: TNC Female
HGA Modem/Power/GPS

Qualification

DO 160D: [C4]XABB[U(F.F1)R(C,C1.E.E1)]S(L,M)]
EWFXXZ[B.A]AAC[TT]H[A3E3]XAA

Certification

677-A0129: Russian IAC PMA
СГКИ-023-171

ZA CAA PMA/546/004

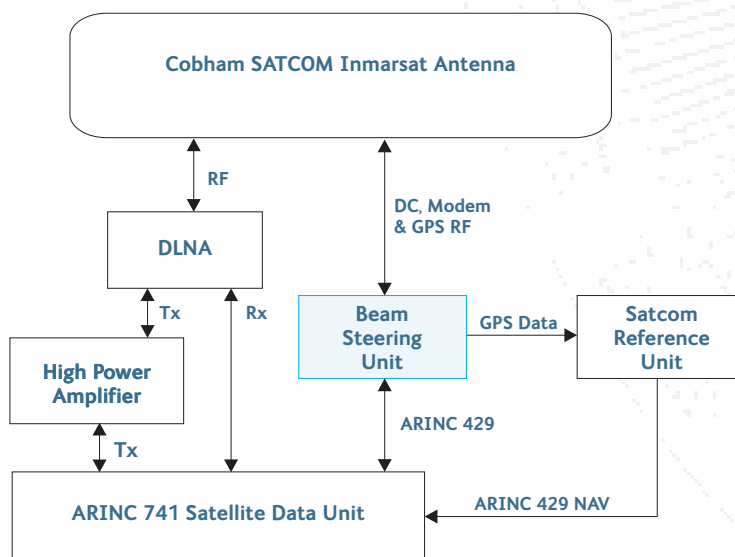

For further information, please contact:

Cobham SATCOM
PO Box 31093
Tokai 7966
Cape Town, South Africa
Tel: + 27 21 700 7000
Fax: + 27 21 700 7199
Email: satcom.capetowninfo@cobham.com
or:

Distributed By: