

THIS DRAWING IS THE SOLE PROPERTY OF GMS INC. THE CONTENTS ARE PROPRIETARY IN NATURE AND ARE NOT TO BE COPIED OR OTHERWISE DUPLICATED OR DISCLOSED TO OTHERS.

**EXPORT ADMINISTRATION REGULATION (EAR) NOTICE**  
 THESE COMMODITIES, TECHNOLOGY OR SOFTWARE ARE EXPORTED FROM THE UNITED STATES IN ACCORDANCE WITH THE EXPORT ADMINISTRATION REGULATIONS. DIVERSION CONTRARY TO U.S. LAW PROHIBITED.

REVISIONS

ECO	REV	DESCRIPTION	DATE	DRAWN	CHKD	PRO ENG	MECH ENG	ENG MGR	DOC
E1523	X5	UPDATE TO INCLUDES SS BAND	10/07/10	DM				TM	SDM
E1759	X6	REMOVE D1, ADD W7	11/7/11	DM					

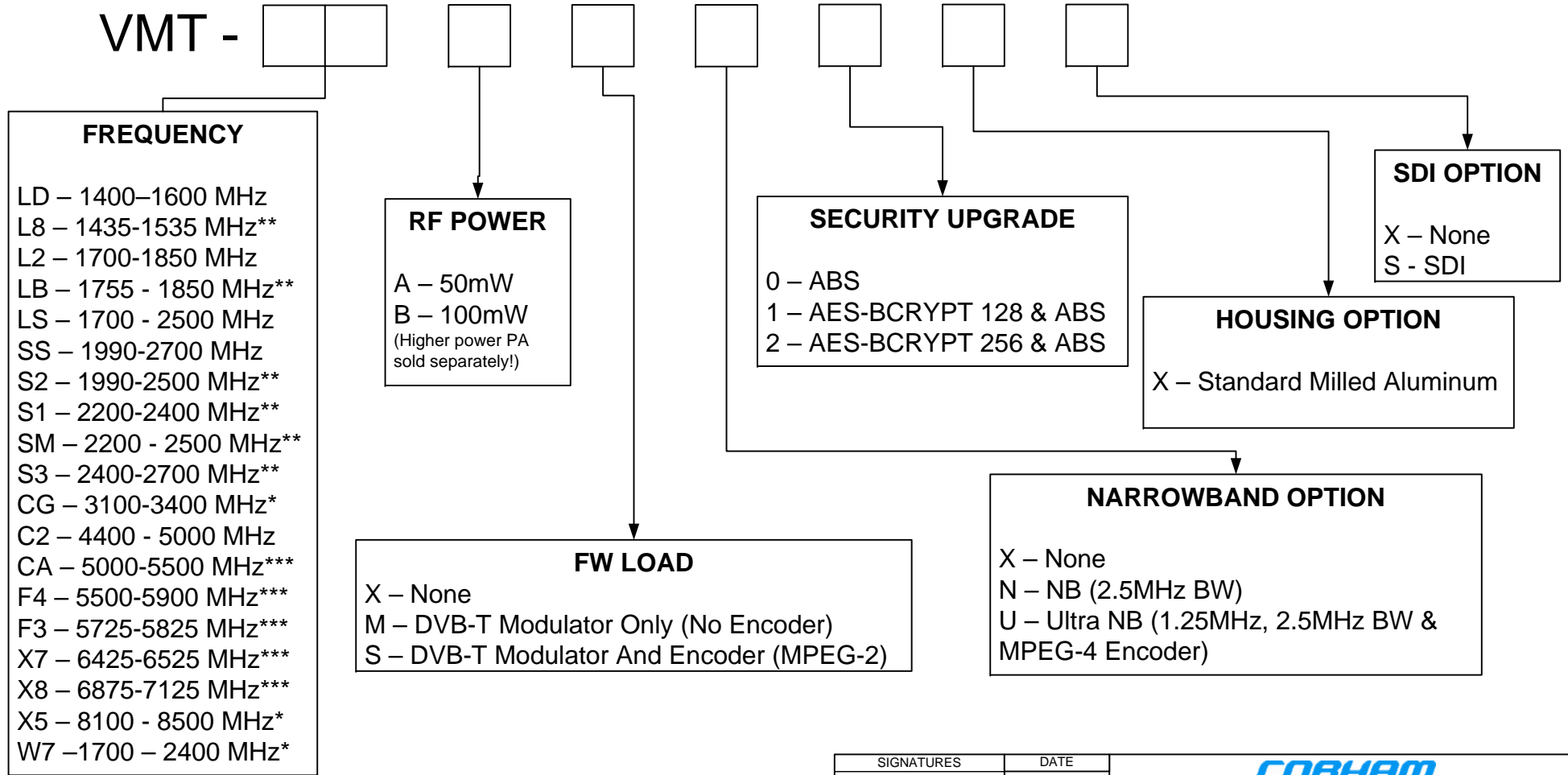

NOTE: \* Future Options  
 \*\* Special – Consult Factory  
 \*\*\* Potential Future Options

SIGNATURES		DATE	 GMS INC. DBA COBHAM TACTICAL COMMUNICATIONS AND SURVEILLANCE 1916 PALOMAR OAKS WAY #100, CARLSBAD, CA 92008 <a href="http://www.cobham.com/tcs">www.cobham.com/tcs</a>		
DRAWN	NM	06/01/2009	DWG TITLE  MNI, VMT		
CHECKED					
PROJ ENG					
ENG MGR					
MECH ENG			SIZE	DWG NO	REV
DOC			<b>B</b>	MNI0086X6	X6
SCALE		NONE	VISIO DWG		SHEET 1 OF 1