

Messenger Veta Receiver Decoder (MVRD)

COBHAM

The most important thing we build is trust.



Product Highlights

- Two Channel Maximal-Ratio Diversity Receiver
- Supports DVB-T and Narrow-Band* modes down to 1.25 MHz BW
- Provides Ultra-Low-Latency for Real-Time Applications (~44 mS) when used with GMS' Messenger or Veta Encoders and Transmitters
- HD/SD AVC H.264 and SD MPEG-2 Decoding
- Compact Design with Local Control & Monitoring

Features

- COFDM Demodulation (*400 or 2K Carriers)
- Bandwidths from *1.25 MHz to 8 MHz
- Input Frequency: 0.174 to 8.5 GHz (In-Bands)
- DVB-ASI and LAN Inputs & Outputs**
- Supports ISO 13818 Transport Stream Demuxing
- HD-SDI, DVI, Component & Composite Video Outputs
- Balanced & Un-Balanced Analog Audio Outputs plus Digital Audio
- Optional Genlock Capability
- Optional Embedded Audio
- Ethernet Port Connectivity (10/100 Mbits/s) for Streaming and Control/Monitoring **

Specifications subject to change without prior notice
Typical values shown unless min or max is specified
100-DS0316X2 09/09/10 1 of 9

Messenger Veta Receiver Decoder (MVRD)



The Messenger Veta Receiver Decoder (MVRD) is a companion product to GMS' Encoders and Transmitters providing the highest Video Quality with Ultra-Low Latency and Fast Recovery essential for Wireless coverage of Real-Time events such as Sports and Surveillance Applications. The MVRD combines all the features and capabilities of GMS' Messenger 2 AVC H.264 HD/SD Decoder with the unique SD capabilities of GMS' MPEG-2/4 SD Veta Receiver. This includes end to end system-level latencies of ~44 mS when used with GMS' Messenger 2 or Veta Encoders/Transmitters.

The MVRD supports direct RF input of standard DVB-T 2K carriers with bandwidths of 6, 7, or 8 MHz. Additionally, optional VETA 1.25 MHz or 2.5 MHz RF bandwidths with 400 carriers that allow both increased reception range and larger quantity of simultaneous Audio/Video links to operate in the same frequency band. The wider bandwidths provide greater throughput that allow the system to transfer the highest quality Video. The standard MVRD is supplied with Dual-Diversity inputs and internal RF Block Down Converters (BDCs). The MVRD's Maximal Ratio Diversity Combiner provides optimum reception in difficult fading and multipath environments. Additionally, the Diversity combining can provide up to 2.5 dB in link performance, increasing the receiver's sensitivity to -97.5 dBm at 8 MHz bandwidth!

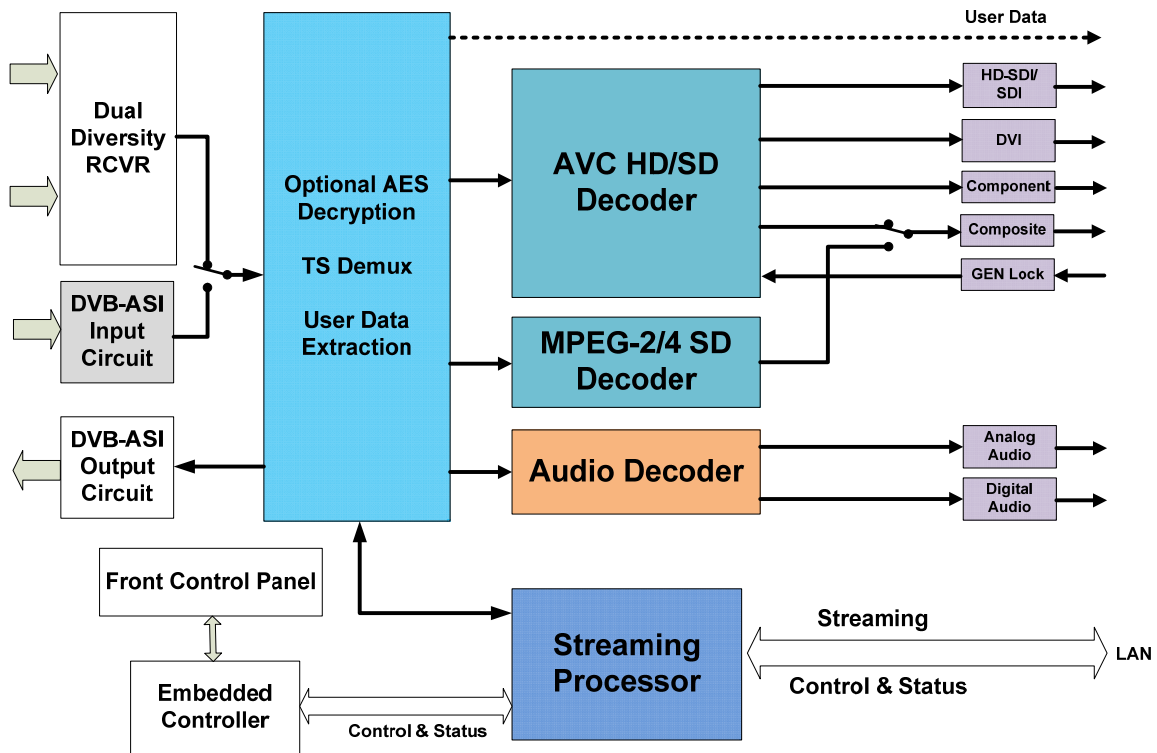

MVRD Block Diagram

Messenger Veta Receiver Decoder (MVRD)



HD & SD AVC H.264 Baseline profile decoding is provided with certain additions and exclusions as described in the Specification section below including interlaced support. AVC H.264 decoding with resolutions from SD up to 1920 x1080, frame rates to 60 frames per second, with progressive or interlaced formats, CBR or VBR all with just 45 mS delay when encoded with a GMS AVC encoder. Additionally, with GMS' AVC Encoders, Instantaneous Decoder Refresh or re-lock can occur on slice boundaries providing the fastest recovery from corrupted streams. Both Frame and Field based Decoding is supported.

The MVRD also includes an optimal Internal Low-Latency Audio/Video (SD Only) MPEG-2/4 Part 10 Decoder and output circuits that provide composite Video and two Audio channels. Optional User Data extraction is available in all Modes. Security of transmission is ensured by the use of Standard ABS encryption or, for greater security, the optional AES 128 or 256 bit scrambling algorithms.

The MVRD includes both DVB-ASI and Ethernet ports for Transport Stream Input/Output** (I/O). The system also offers a choice of transport protocols with support for AVC/MPEG embedded within a MPEG-2 TS (ASI or IP) and raw H.264 bit streams (IP Only)**. LAN based transport streams can be delivered with either UDP or RTP/UDP Protocols**. A compressed TS stream can be input from the DVB-ASI interface, and reformatted for IP Streaming** and Output at the same time that it is being locally decoded. The Decoder incorporates error resiliency features. In the event of a damaged bit-stream, the Decoder can replace the corrupt slice with skips, and resume decoding at the next NAL unit. Alternatively it can freeze the output until a new I-frame is received.

The Decoder can be set to tune both Video and Audio by two ways: Auto and PID locking**. In *Auto* mode the unit will self acquire the First MPEG program in the transport stream and the First Audio PID listed in the PMT for that Program. For Multiple Program Streams (MPTS), the program number can be selected. Within the selected MPEG program, each of the Two Audio Processors can have an Audio PID from that program selected.

In *PID Locking Mode*** the MVRD can be set to select Video from a specific PID, and select Audio for the 1st and 2nd Audio processor from specific setting. This setting can be set manually using numeric PID values. In this mode the MVRD will only decode Video or Audio that has been manually set.

The MVRD can be controlled either through its Front Panel Control Interface or through its USB or LAN interfaces.** Additionally, it has Two LED Status Lights. One LED is for Input which is Green when the selected Input is OK (present and valid for transport stream interfaces, and meets settable criteria). The second Red LED Status Light is for Error Conditions.

Messenger Veta Receiver Decoder (MVRD)



MVRD Rear Panel

Messenger Veta Receiver Decoder (MVRD)



Specifications:

COFDM RF Input

Input Ports:	2
Connectors:	SMA-F
Input Impedance:	50 Ohms, <1.5:1 VSWR
Input Frequency:	0.9 to 8.5 GHz (In-Bands)
Frequency Accuracy:	(+/-) 5 ppm

Demodulation

DVB-T # of Carriers:	2k
DVB-T Bandwidth:	8/ 7/ 6 MHz
DVB-T Guard Interval:	1/32, 1/16, 1/8, 1/4
DVB-T FEC:	1/2, 2/3, 3/4, 5/6
DVB-T Modulation:	QPSK, 16-QAM, 64-QAM

Optional VETA Narrow BW Modes

VETA # of Carriers:	400
VETA Bandwidth:	2.5 MHz or 1.25 MHz
VETA Guard:	1/16, 1/8
VETA FEC:	1/3, 2/3
VETA Modulation:	QPSK, 16-QAM
Threshold:	(6,7, & 8 MHz BW)
QPSK ½:	<-95 dBm
16-QAM ½:	<-89 dBm
64-QAM ½:	<-83 dBm

(Optional Diversity can improve threshold by 2.5 dB)

VETA BW Threshold: -100 dBm to -105dBm

Serial Transport Stream I/O

General

Ports: RF, DVB-ASI or LAN IP**, selectable

ASI Serial TS Input/Output

of ASI Inputs: 1, BNC-F
of ASI Outputs: 1 (loop-through), BNC-F
Max TS Rate: Up to 150 Mbps

LAN/ IP Serial Input/Output**

of Ethernet Ports: 1, RJ-45

Messenger Veta Receiver Decoder (MVRD)



Streaming Format: RTP/UDP/IP or UDP/IP Unicast or Multicast
Supports MPEG-2 Transport Stream over UDP or RTP
Output: DVB-ASI input can be reformatted for streaming and output at the same time that it is being Decoded.

Single or Multiprogram Support

AVC Decoder (Video, 2 Audio)

General

Compatibility Standard: MPEG-4 AVC/H.264 Baseline Profile Plus Interlace Support
Bit streams Accepted: AVC video in MPEG TS per ISO/IEC 13818-2 PES packets per ISO/IEC 13818-1
Video Bit Rate: 1 Mbps to 60 Mbps

Video Decoder

Format @ Frame rate: 1080P @ 30Hz, 29.97Hz, 25Hz, 24Hz, 23.98Hz
1080I @ 30Hz, 29.97Hz, 25Hz
720P @ 60Hz, 59.94Hz, 50Hz, 30Hz, 29.97Hz, 25Hz, 24Hz, 23.98Hz
480I @ 29.97Hz
576I @ 25Hz
Display modes supported: Letterbox, Cropped
Aspect Ratio: 16x9, 4x3 (selectable - format dependant)
Systems Latency end to end delay: ~44ms (w/Messenger AVC TX Only, mode dependant)

AVC Video Output

General

Output connectors: Qty 1 HD-SDI, Qty 1 HDMI, Qty 1 Component, Qty 1 SD Only, Qty 2 Composite
Output formats supported: 1920 x 1080 Progressive
1920 x 1080 Interlaced
1280 x 720 Progressive
720 x 480 Progressive
720 x 480 Interlaced
720 x 576 Interlaced
Frame rates: 60/50/30, 59.94/29.97, 25Hz fps
(Progressive/Interlaced)
(1080p limited to 30 frames per second Max)
Aspect Ratio: 16x9 (fixed: 1080I, 720P)

Messenger Veta Receiver Decoder (MVRD)



Display Modes (selectable): 16x9, 4x3 (selectable: 480P)
HD: Letterbox**, Cropped, Full
SD: Letterbox**, Cropped

HD-SDI (High Definition Serial Digital Interface)

Standard: SMPTE 292M
Data Bit Rate: 1.485 Gbps
of Serial Outputs: 1
Connector: BNC (x1), female

Embedded Audio (Option)

Embedded audio format: SMPTE 299M
Sample rates supported: 32, 44.1, 48 KHz
Sample rate out: 48 KHz
embedded audio: 4 (2 stereo pairs)
Audio types supported: MPEG2 layer 1 and 2, or ADPCM (Future Option)
Embedded audio control: Selectable, .type./disable (each pair independently controlled)

Analog Video

SD
Video format standards: PAL & NTSC Composite
of Analog outputs: 2
Connectors: RCA-F

HD/SD
Video format standards: Component
of Analog outputs: 1 set (Y, Pb, Pr)
Connectors: RCA-F

DVI (Digital Visual Interface)

DVI Connector: DVI-I Socket - female

Note: Can be converted to HDMI (Video Only) with external adapter (Sold Separately)

MPEG-2/4 Video Decoding

Compression Standard: MPEG-2 or MPEG-4
Chrominance Profile: 4:2:0
Line Standard: 525 and 625 (NTSC/PAL)
Horizontal Resolution: 704, 528, 480, 352 pixels
Systems Latency end to

Messenger Veta Receiver Decoder (MVRD)



end delay: ~40ms for 6,7, or 8 MHz, Narrow BW to ~120 mS (w/VETA TX Only, mode dependant)

Video Outputs: Composite w/OSD

Standards: NTSC (with and without pedestal) or PAL

Video Connectors: Qty 2 Composite RCA-F (One on Front Panel, One on Rear Panel)

Output Impedance: 75 Ohms

Output Level: 1 Vpp

Frequency Response: 10 Hz to 4 MHz, (+/-) 1.5 dB

Audio Decoder

Decoder Capabilities: MPEG-1, layers I and II
MPEG-2, layer II,
NICAM (Veta Mode Option)**

MPEG-2 PES Formats: MPEG-2, MPEG-1

Audio Source: Selected Audio Services 1-4

Audio Output General

of Services: AVC Mode: 4 Mono or 2 Sterio Pairs
MEPG-2/4 Mode: 2 Mono or 1 Sterio Pairs

Analog Audio Out

Output Type: Balanced, 2 channel pairs (+/-) Left/Right

Connectors: Qty 2 XLR-M
Qty 2 p/o High density 15-pin D-sub, female

Cable w/Optional connectors: DB-15 to Qty 2 - XLR-M

Impedance: 600 Ohms nominal

Remote Operation/Update Interface

Type: Ethernet, 10/100 BaseT

Connector: RJ45

Serial Remote operation interface

Type: USB

Connector: USB-A

Front Panel Indicators .

Input LED: Green indicates valid input on selected input,
Off indicates no valid signal on the selected input

Error LED: Red indicates error is occurring
OFF indicates no errors detected

Messenger Veta Receiver Decoder (MVRD)



Power

DC Input:	+9 to +36 VDC
DC Power:	15 Watts
AC Input Option:	Via External Power Supply
Voltage Range:	100 - 120/ 200 – 240 VAC
Power:	Maximum – 200 W
Frequency:	47 – 63 Hz
Line cord:	Detachable, 3-prong
Cooling:	Forced air

General

Operating Temperature:	0 to 50 degrees C
Operating Humidity:	95% Non-Condensing

GENLOCK Option (Option)**

Genlock capability:	AVC HD/SD Only
Genlock Reference:	480i @ 29.97, Ref NTSC “black and burst” 1080i @ 29.97 fps Ref NTSC “black and burst” or 1080i tri-level sync @ 29.97 fps 1080i @ 30 fps – Ref 1080i tri-level sync @30fps 1080i @ 50 fps – Ref 1080i tri-level sync @50fps 720p @ 50 fps – Ref 720p tri-level sync @ 50 fps 720p@ 59.94 fps–Ref 720 tri-level sync @ 59.94 fps 720p @ 60 fps – Ref 720 tri-level sync @ 60 fps
Size:	8.5” W x 10 ¾” L x 1 ¾” H 21.3 cm W x 27.5 cm L x 4.5 cm H

*: Option

**: In Development. This feature will be supplied as a field FW update, when available.