

COBHAM

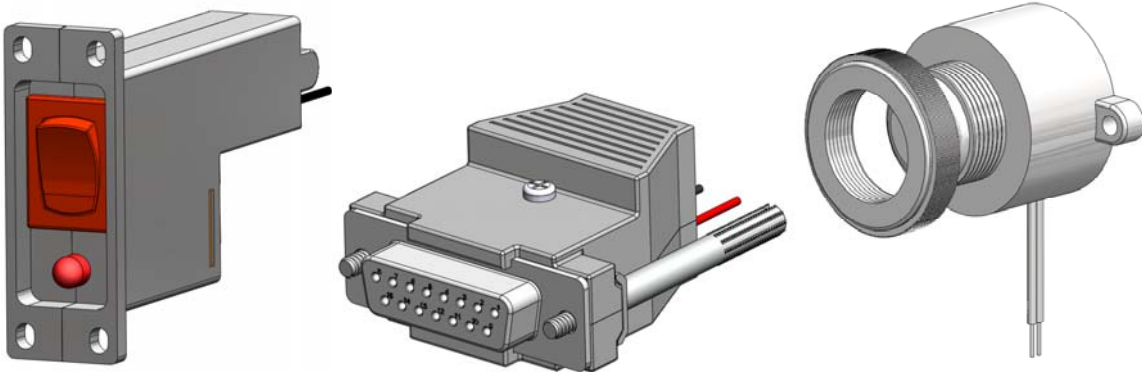

**DESCRIPTION, INSTALLATION, OPERATION, AND
MAINTENANCE MANUAL**

**REMOTE SWITCH 453-0023, MODULE INTERFACE 453-1101
AND BUZZER 452-6505 INSTALLATION**

570-0023 Rev. D

**Cobham Avionics
Artex Products**

**Artex Aircraft Supplies, Inc.
doing business as Cobham Avionics
14405 Keil Road NE Aurora, Oregon 97002 USA
Phone 503-678-7929, Fax 503-678-7930
E-mail info@artex.net
www.artex.net**

Notices

1. This document discloses subject matter in which Artex Aircraft Supplies, Inc. has proprietary rights. Neither receipt nor possession thereof confers or transfers any right to reproduce or disclose the document, any part thereof, any information therein, or any physical article or device, or practice any method or process except by written permission from or written agreement with Artex Aircraft Supplies, Inc.
2. This manual is subject to regular updates and changes.
3. Cell Warning:



**131-0001 CELL WARNING:
DO NOT RECHARGE, SHORT-CIRCUIT, DISASSEMBLE, DEFORM,
HEAT OR PLACE NEAR A DIRECT FLAME**

List of Effected Pages

PAGE #	DATE	REASON FOR CHANGE
TITLE	04/16/09	DCN 2818, 2929, 3418
1	04/16/09	DCN 2819, 2825, 3418
2	04/16/09	DCN 2818, 2929, 3418
3	04/16/09	DCN 2818, 2929, 3068, 3418
4	04/16/09	DCN 2818, 2929, 3068, 3418
5	04/16/09	DCN 3068, 3418
6	04/16/09	DCN 3068, 3418
7	04/16/09	DCN 3068, 3418
8	04/16/09	DCN 2819, 2825, 3068, 3418
9	04/16/09	DCN 3068, 3418
10	04/16/09	DCN 3068, 3418
11	04/16/09	DCN 3068, 3418
12	04/16/09	DCN 3068, 3418
13	04/16/09	DCN 3068, 3418
14	04/16/09	DCN 3068, 3418
15	04/16/09	DCN 3068, 3418
16	04/16/09	DCN 3068, 3418
17	04/16/09	DCN 3068, 3418
18	04/16/09	DCN 3068, 3418
19	04/16/09	DCN 3068, 3418
20	04/16/09	DCN 3068, 3418
21	04/16/09	DCN 3068, 3418
22	04/16/09	DCN 3068, 3418
23	04/16/09	DCN 3068, 3418
24	04/16/09	DCN 3068, 3418
25	04/16/09	DCN 3068, 3418
26	04/16/09	DCN 3068, 3418
27	04/16/09	DCN 3068, 3418
28	04/16/09	DCN 3068, 3418
29	04/16/09	DCN 3068, 3418
30	04/16/09	DCN 3068, 3418

PAGE #	DATE	REASON FOR CHANGE
31	04/16/09	DCN 3418
32	04/16/09	DCN 3418
33	04/16/09	DCN 3418

Revision History

REVISION	ENGINEERING CHANGE ORDER	DATE
-	RELEASE	06/02/06
A	DCN 2819, 2825	11/01/06
B	DCN 2818, 2929	01/29/07
C	DCN 3068	02/14/08
D	DCN 3418	04/16/09

Table of Contents

1.	INTRODUCTION.....	8
2.	PARTS LIST.....	8
3.	WIRING PIN OUT.....	9
4.	HARNESS	10
5.	WIRING DIAGRAM	11
6.	453-0023 REMOTE SWITCH INSTALLATION.....	13
6.1	AMERI-KING AND ACK INSTALLATION RETROFIT.....	13
6.2	TYPICAL INSTALLATION.....	15
6.3	PANEL CUTOUT INSTRUCTIONS	16
7.	INSTALLATION	18
7.1	INSTRUCTIONS.....	18
8.	453-1101 MODULE INTERFACE INSTALLATION	20
8.1	INSTRUCTIONS.....	20
9.	453-1101 MODULE INTERFACE AND 452-6505 BUZZER WIRING.....	21
9.1	INSTRUCTIONS.....	21
10.	REMOTE SWITCH CELL REPLACEMENT	21
10.1	CELL SHELF LIFE	21
10.2	MATING COVER REMOVAL.....	22
10.3	CELL REPLACEMENT FROM CELL HOLDER WITH STAND ALONE SPRING	22
10.4	CELL REPLACEMENT FROM CELL HOLDER WITH BUILT-IN SPRING.....	26
10.5	MATING COVER INSTALLATION	29
10.6	CELL DISPOSAL INSTRUCTIONS.....	30
11.	TROUBLESHOOTING GUIDE	30
12.	SPECIFICATIONS.....	31
12.1	COMPONENTS DIMENSIONS.....	31
12.3	ENVIRONMENTAL CATEGORIES.....	32
13.	INDEX	33

List of Figures

Figure 1: Wiring diagram for shielded cable (Composite Aircraft).....	11
Figure 2: Wiring diagram for unshielded telephone line (Composite Aircraft).....	11
Figure 3: Wiring diagram for shielded cable (Metallic Aircraft).....	12
Figure 4: Wiring diagram for unshielded telephone line (Metallic Aircraft).....	12
Figure 5 : Label 591-0003 & 591-3029.....	16
Figure 6 : Panel cutout dimensions.....	16
Figure 7 : Harness to remote switch connection.....	18
Figure 8 : Remote switch orientation.....	18
Figure 9 : Remote switch wire tensile load release.....	19
Figure 10: Module interface to ELT connection.....	20
Figure 11: Module interface wire tensile load release.....	20
Figure 12: Spring Configuration.....	22
Figure 13: Conical spring.....	23
Figure 14: Conical spring installation.....	23
Figure 15: Cell holder wires.....	24
Figure 16: Ground wire.....	25
Figure 17: Cell installation.....	26
Figure 18: Spring installation.....	26
Figure 19: Spring fit.....	27
Figure 20: Cell holder wires.....	27
Figure 21: Ground wire.....	28
Figure 22: Mating cover installation.....	29
Figure 23: Retaining screws installation.....	29
Figure 24: 453-0023 Remote Switch.....	31
Figure 25: 453-1101 Module Interface.....	31

1. INTRODUCTION

This manual contains detailed information to install the self-powered remote switch 453-0023, module interface 453-1101, and the buzzer 452-6505. In addition, these instructions highlight the methodology to replace the cell in the remote switch. This manual is not intended to be an installation for the ELT system.

Use this manual in conjunction with any of Artex ME406 series ELT manuals.

2. PARTS LIST

The following parts should be included with the 455-0023 and 455-7420 Pack Lists. Please contact Artex Aircraft Supplies, Inc. if shortages are found.

<u>QUANTITY</u>	<u>PART NUMBER</u>	<u>DESCRIPTION</u>
	455-0023	Pack List, Self-Powered Remote Switch
4 ea.	209-0002	Screw, 4-40 X 1/2, SOC, SS, BLK
4 ea.	241-0400	HEX Nut, 4-40 Reduced Dim.
1 ea.	453-0023	Remote Switch, Self-Powered Assembly
1 ea.	570-0023	Manual, Remote Switch 453-0023, Module Interface 453-1101 and Buzzer 452-6505 Installation
1 ea.	591-0003	Label, 453-0023 Remote Switch Horizontal
1 ea.	591-0036	Label, Cell Replacement Warning
1 ea.	591-3029	Label, 453-0023 Remote Switch

<u>QUANTITY</u>	<u>PART NUMBER</u>	<u>DESCRIPTION</u>
	455-7420	Pack List, ME406 Install Kit
4 ea.	201-0810	Screw, PHP 8-32 x 5/8 SS
4 ea.	241-0832	Nut, HEX 8-32 x 1/4 SS
4 ea.	246-0008	Washer, Flat, SS .036"-.045"
2 ea.	850-0814	Sealant Strip, D-sub Connector

3. WIRING PIN OUT

The following information highlights the pin out of the remote switch and module interface.

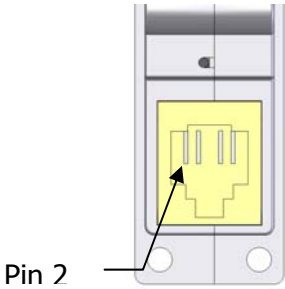
Remote Switch Back View		
VIEW	PIN #	SIGNAL DESCRIPTION
	2	Light
	3	External On
	4	Reset 1
	5	Reset 2

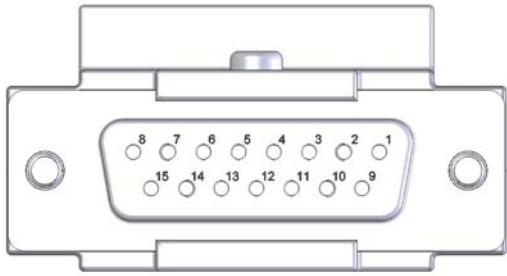
Module Interface Front View		
VIEW	PIN #	SIGNAL DESCRIPTION
	2	Light
	5	G-Switch Loop
	6	Reset 1
	7	Ground
	8	Horn Power
	12	G-Switch Loop
	13	Reset 2
	14	External ON

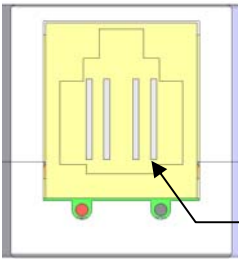
Module Interface Back View		
VIEW	PIN #	SIGNAL DESCRIPTION
	2	Light
	3	External On
	4	Reset 1
	5	Reset 2

4. HARNESS

Due to the large array of configurations possible, Artex Aircraft Supplies, Inc. does not provide a harness or RJ11 plugs (telephone connector) as part of the installation of the ELT. Accordingly, it is the responsibility of the installer to manufacture a harness or ensure that the existing harness is adequate for the installation.

The harness must be manufactured following the cross-wired configuration mentioned in section 6.2.

NOTE: Refer to section 6.1 for Ameri-King and ACK retrofit installations.

Artex recommends using a shielded cable to prevent signals related to power frequency, audio frequency and electrical transients generated from on-board equipments from interfering with the ELT operation.

Although it might be appropriate to use a telephone line (minimum UL flammability rating VW-1) in some instances, each installation is different and should be evaluated on a case by case basis. Accordingly, it is the responsibility of the ELT installer to ensure that the installations follow FAA regulations such as but not limited to Advisory Circular 43.13-2A.

Refer to the installation section of any of the ME406 series manuals for ELT related information.

5. WIRING DIAGRAM

Refer to the following wiring diagrams to connect the remote switch 453-0023, module interface 453-1101, and buzzer 452-6505 to the ME406 series ELT.

NOTE: For Ameri-King or ACK ELT retrofit application, refer to section 6.1.

Figure 1 and 2 apply to composite aircrafts, whereas Figure 3 and 4 apply to metallic aircrafts.

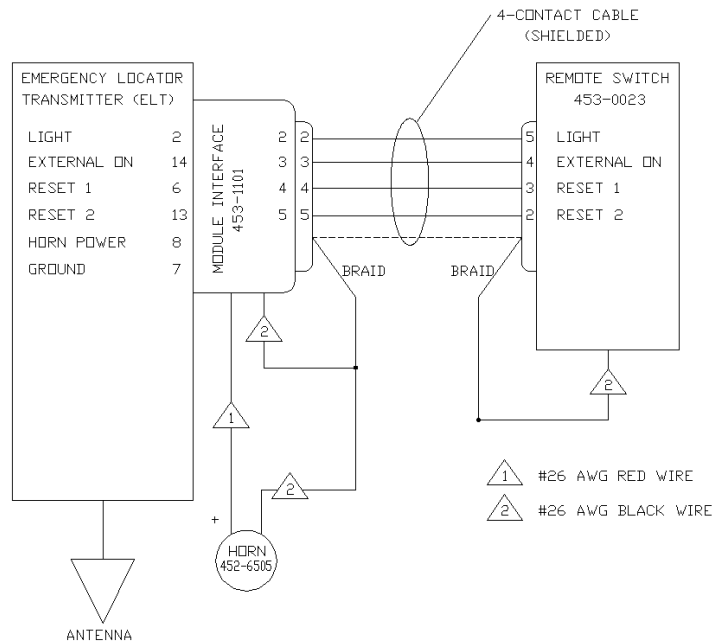

Figure 1: Wiring diagram for shielded cable (Composite Aircraft)

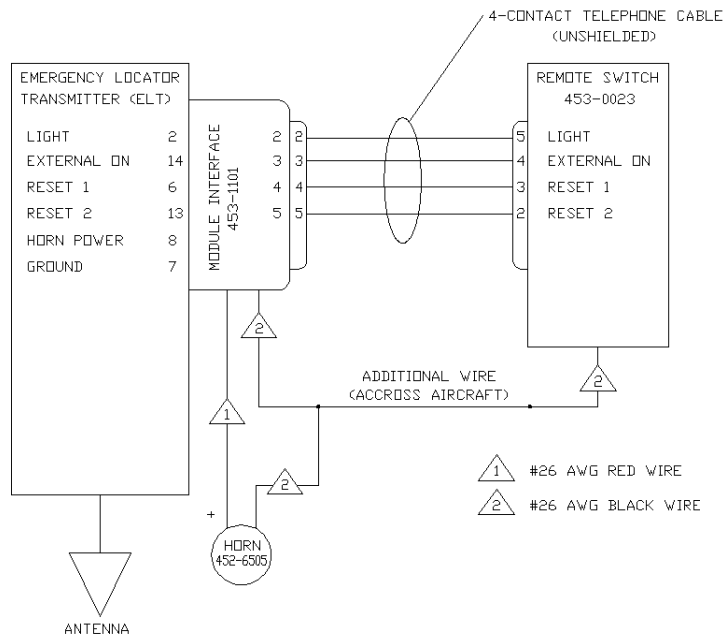

Figure 2: Wiring diagram for unshielded telephone line (Composite Aircraft)

Figure 3 and 4 apply to metallic aircrafts.

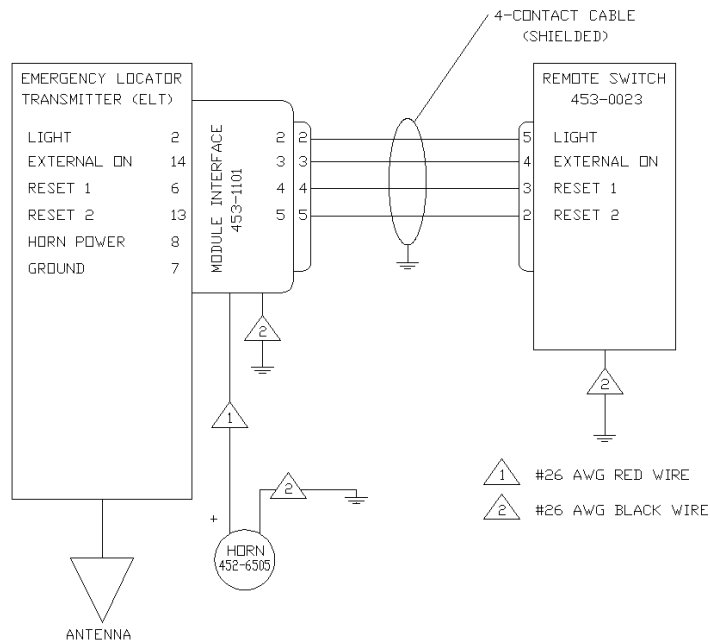

Figure 3: Wiring diagram for shielded cable (Metallic Aircraft)

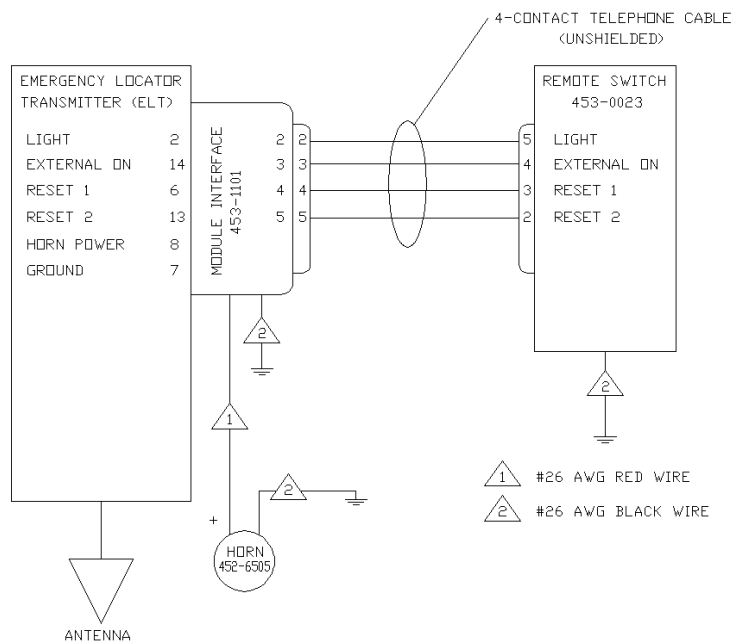

Figure 4: Wiring diagram for unshielded telephone line (Metallic Aircraft)

6. 453-0023 REMOTE SWITCH INSTALLATION

6.1 Ameri-King and ACK Installation Retrofit

Ameri-King retrofit:

The remote switch 453-0023 and ME406 series ELT cannot be used in conjunction with the Ameri-King interconnecting cable unless extender 611-0018 is connected directly with the Ameri-King cable. This 611-0018 extender is provided as part of the ELT installation pack list or can be ordered as line item.

The 611-0019 flat cable can be discarded since it is intended for ACK retrofit.

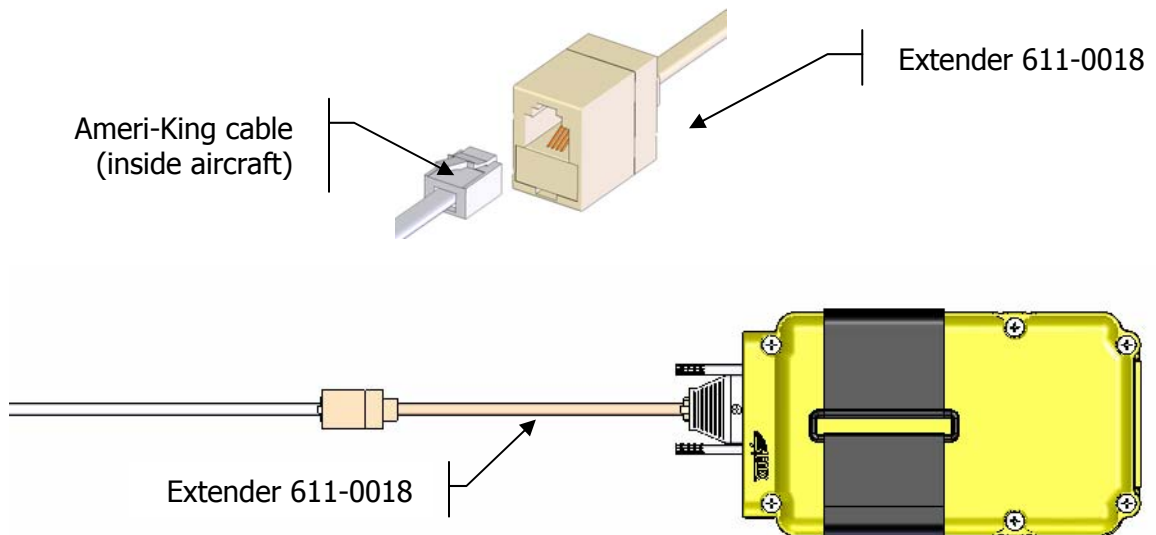

ACK retrofit:

The remote switch 453-0023 and ME406 series ELT cannot be used in conjunction with the ACK interconnecting cable unless Flat Cable 611-0019 is connected directly with the ACK cable. This 611-0019 cable is provided as part of the ELT installation pack list or can be ordered as line item. The cable is installed on the ELT side.

The 611-0018 extender can be discarded since it intended for Ameri-King ELT retrofit.

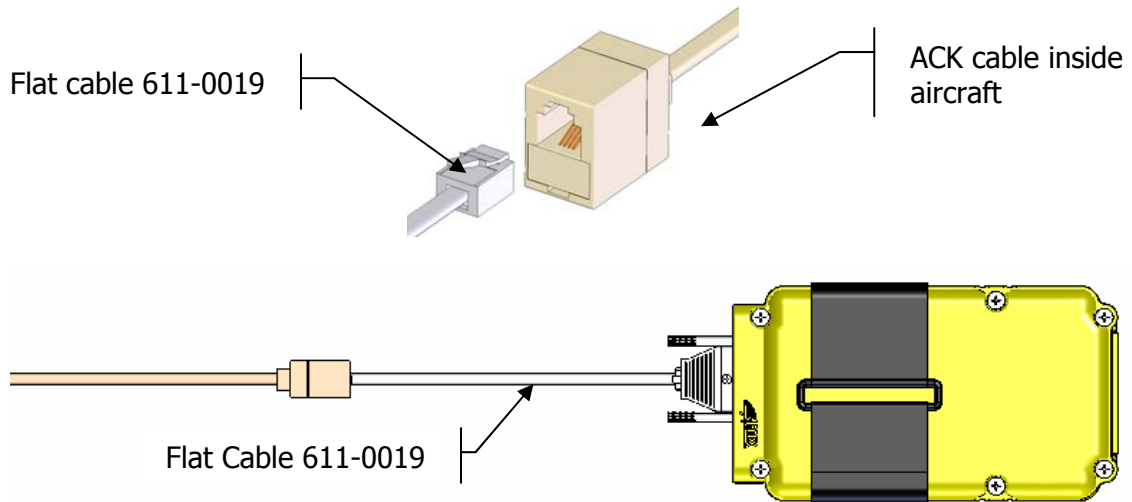

611-0019 Wiring	
C1	C2
2	5
3	4
4	3
5	2

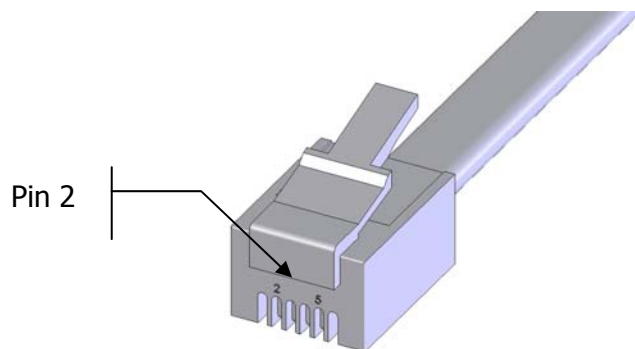

6.2 Typical Installation

- 6.2.1 Due to the large array of configurations possible, Artex Aircraft Supplies, Inc. does not provide a harness or RJ11 plugs (telephone connector) as part of the installation of the ELT.
- 6.2.2 The harness must be manufactured following the cross-wired configuration shown below.

NOTE: Refer to section 6.1 for ACK and Ameri-King retrofits.

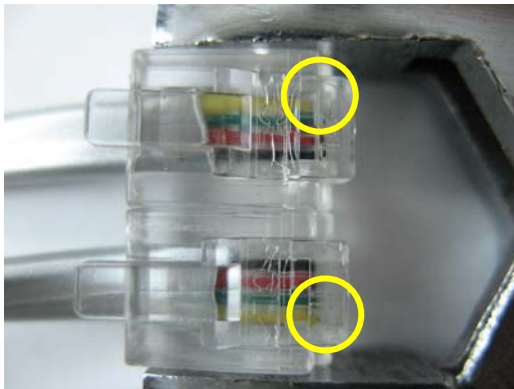

○ Location indicator for black & white prints

611-0019 Wiring	
C1	C2
2	5
3	4
4	3
5	2

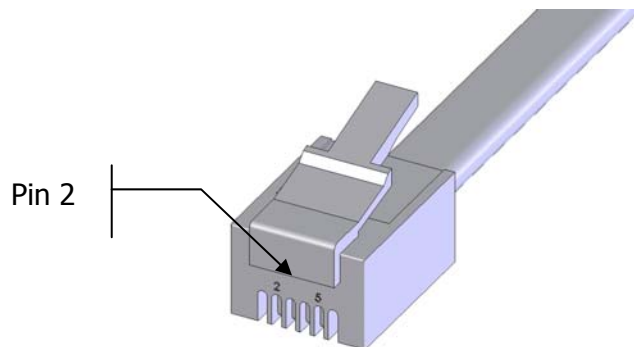

6.3 Panel Cutout Instructions

6.3.1 Select a mounting location where the remote switch can be seen from the pilot's seated location, easily be reached by the pilot, out of direct sunlight, and can accommodate the remote switch and the label. Depending on the remote switch orientation on the control panel, choose the appropriate label and discard the other one. Label 591-0003 and label 591-3029 are provided in the 455-0023 pack list.

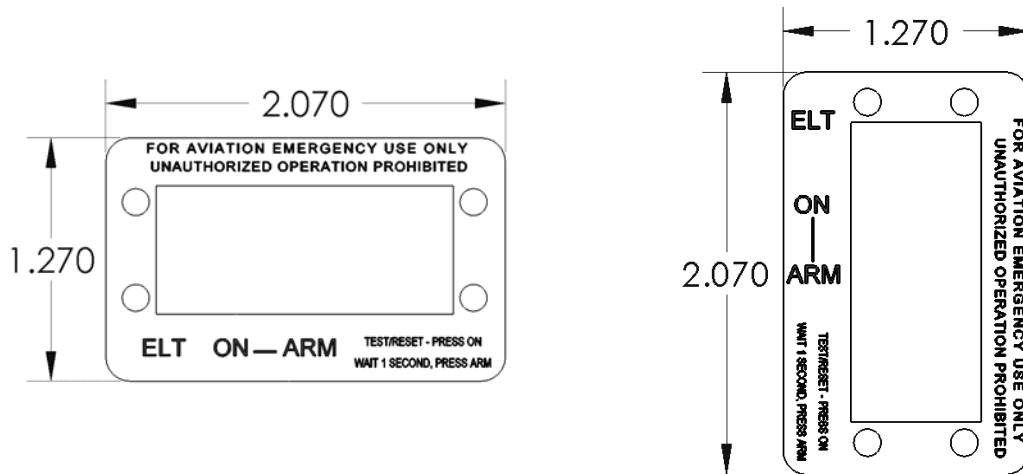
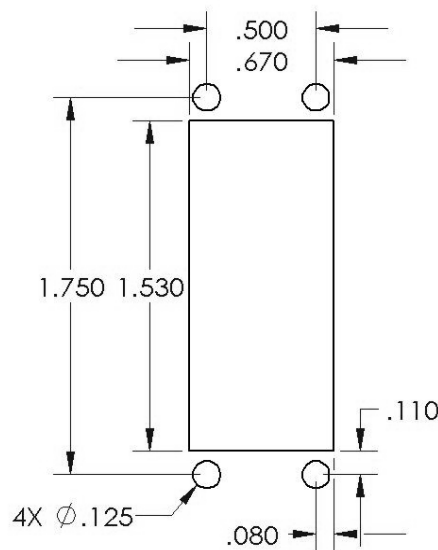

Figure 5 : Label 591-0003 & 591-3029

6.3.2 Create a cutout in the panel for the remote switch according to the minimum dimensions specified below and drill four 1/8" diameter holes. The dimensions apply to both 591-0003 and 591-3029 labels. Adjust the hole-pattern appropriately on the panel depending on the orientation of the remote switch.

NOTE: For Ameri-King retrofit applications, use the existing mounting holes since the face plate of the remote switch is designed to accommodate that hole-pattern.



Tolerance: +.020, -.000

Figure 6 : Panel cutout dimensions

- 6.3.3 Clean the application surface area thoroughly prior to applying label 591-0003 or 591-3029.
- 6.3.4 Remove the paper backing from the label and line up the label over the cutout.
- 6.3.5 Press firmly and evenly over the label to produce maximum adhesion.
- 6.3.6 Trim the label with an Exacto knife if it partially covers the mounting holes.

7. INSTALLATION

7.1 Instructions

- 7.1.1 Feed the modular jack connector from the harness through the panel cutout.
- 7.1.2 Plug the modular jack connector to the remote switch.

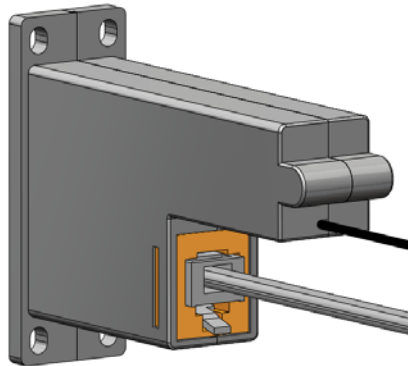

Figure 7 : Harness to remote switch connection

- 7.1.3 Slide the remote switch and the harness inside the cutout following the orientation shown below.

NOTE: The LED must be located under the **ARM** lettering of the label.

- 7.1.4 Secure the remote switch using the hardware provided in the 455-0023 pack list. Use a 1/16 hex socket for the nuts and a small Phillips screwdriver for the screws. The torque on the screws is 4.0 Lb-in (± 0.5 Lb-in).

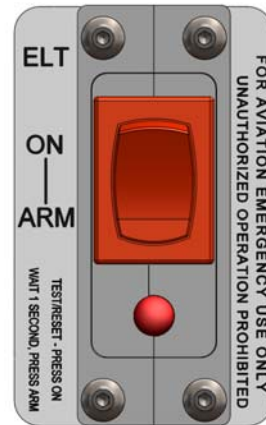
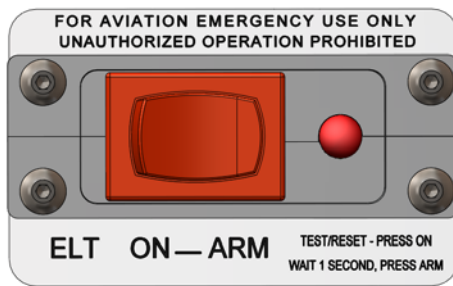

Figure 8 : Remote switch orientation

- 7.1.5 Fasten the ground wire along the harness within one inch of the remote switch using a tie cable.

NOTE: The ground wire should have enough slack to prevent tensile load.

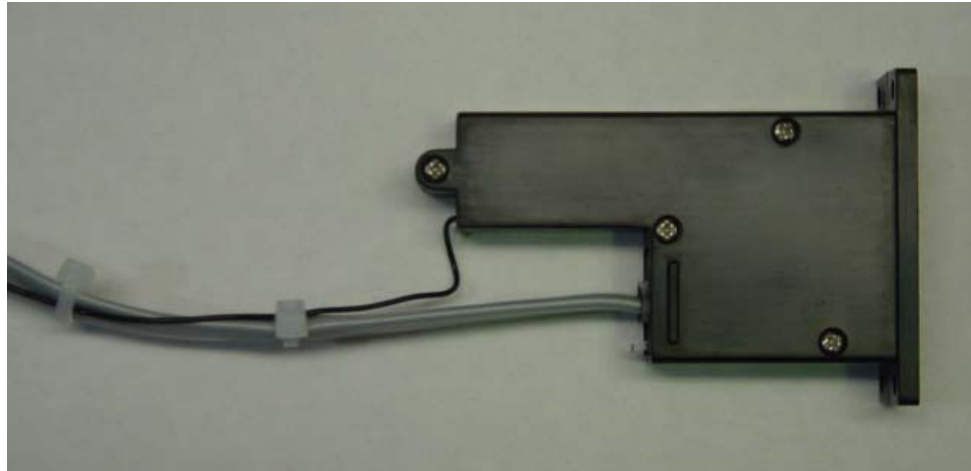

Figure 9 : Remote switch wire tensile load release
(Panel not shown)

- 7.1.6 Connect the remote switch 26 AWG ground wire according to the wiring diagrams highlighted in section 5 using a ring or a fork terminal quick disconnect.
- NOTE:** Secure an additional wire to the ground wire with a butt slice to extend the length if necessary.
- 7.1.7 Fasten the harness to the aircraft. Ensure that the harness has enough slack to prevent tensile load on the modular jack connector of the remote switch.
- 7.1.8 Plug the modular jack connector of the harness to the module interface 453-1101 if it is already installed.
- 7.1.9 Refer to the Transmitter Test section of the ME406 series ELT manuals to check the operation of the complete connection to the ELT.
- 7.1.10 Apply Cell Replacement Warning label 591-0036 from kit 455-0023 inside the aircraft's logbook. The intent of the label is to remind the pilot to change the cell inside the remote switch every five years or sooner depending on usage.
- 7.1.11 Enter the date, installer's initials and whether the ELT passed or failed into the aircraft's logbook.

8. 453-1101 MODULE INTERFACE INSTALLATION

8.1 Instructions

- 8.1.1 Place the two sealing strips 850-0814 provided in the 455-7420 install kit into the ELT 15-pin D-sub connector.
- 8.1.2 Insert the module interface 453-1101 into the ELT D-sub and secure it in place using the two thumbscrews. The torque on the thumbscrews is 4 to 5 Lb-in.

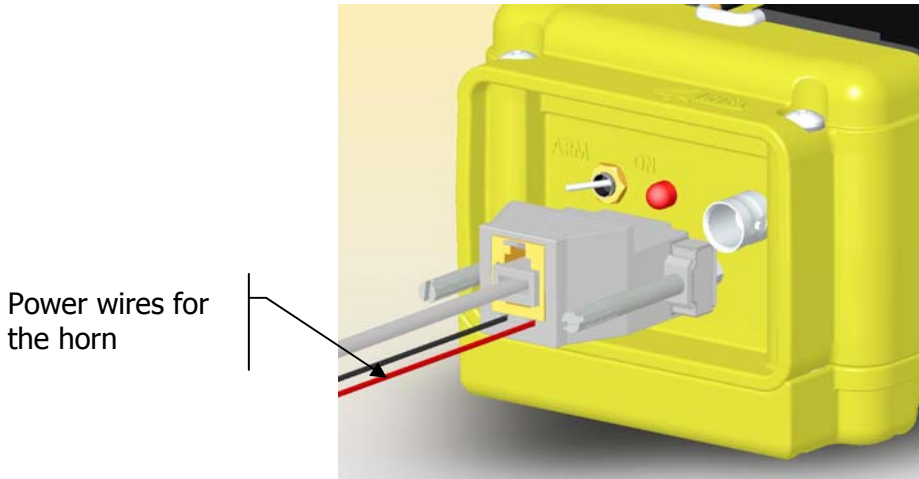

Figure 10: Module interface to ELT connection

- 8.1.3 Fasten the two wires along the harness within one inch of the module interface using a tie cable.

NOTE: The wires should have enough slack to prevent tensile load.

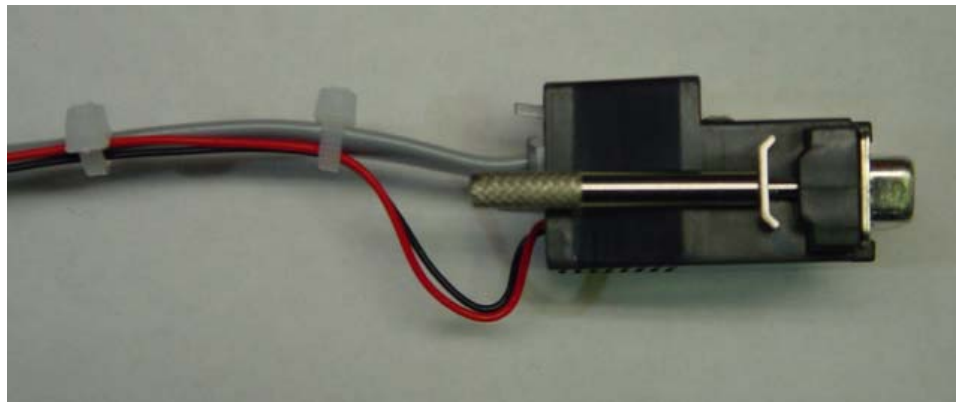

Figure 11: Module interface wire tensile load release (ELT not shown)

- 8.1.4 Fasten the harness to the aircraft. Ensure that the harness has enough slack to prevent tensile load on the modular jack connector of the module interface.
- 8.1.5 Plug the modular jack connector of the harness to the remote switch 453-0023 if it is already installed.

- 8.1.6 Refer to the Transmitter Test section of the ME406 series ELT manuals to check the operation of the complete connection to the ELT.
- 8.1.7 Enter the date, installer's initials and whether the ELT passed or failed into the aircraft's logbook.

9. 453-1101 MODULE INTERFACE AND 452-6505 BUZZER WIRING

9.1 Instructions

- 9.1.1 Follow the appropriate wiring diagrams highlighted in section 5 depending if the aircraft is metallic or composite.



Follow the correct polarity by connecting the black wires together, followed by the red wires together.

- 9.1.2 Mount the buzzer according to the instructions highlighted in the ME406 series ELT manuals.

NOTE: Allow enough slack to prevent tensile load on the wires leading from the module interface and the buzzer. Depending on the location of the buzzer, additional wires can be strung between the buzzer and the module interface.

10. REMOTE SWITCH CELL REPLACEMENT



**131-0001 CELL WARNING:
DO NOT RECHARGE, SHORT-CIRCUIT, DISASSEMBLE, DEFORM,
HEAT OR PLACE NEAR A DIRECT FLAME**

10.1 Cell Shelf Life

- 10.1.1 The shelf life of the cell is 5 years. The cell is available through Artex Aircraft Supplies, Inc. under part number 131-0001.
- 10.1.2 The Lithium content of the cell is less than 0.15 Gram.

10.2 Mating Cover Removal

- 10.2.1 Remove the four retaining nuts and screws securing the remote switch 453-0023 to the panel.
- 10.2.2 Slide the remote switch from the panel.
- 10.2.3 Cut the tie cables securing the ground wire to the harness.
- 10.2.4 Disconnect the modular jack connector of the harness from the remote switch.
- 10.2.5 Remove the four retaining screws from the remote switch to access the cell compartment.
- 10.2.6 Remove the protective cover opposite of the product label.

10.3 Cell Replacement from Cell Holder with Stand Alone Spring

- 10.3.1 At this point, two options are available depending on the manufacturing date of the remote switch:

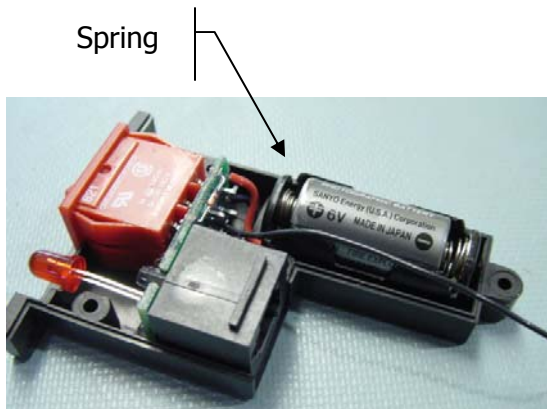

The remote switch was manufactured with an individual spring unattached to the cell holder. Accordingly, proceed with the following instructions.

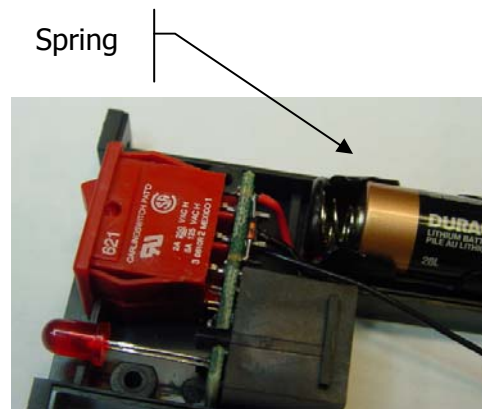

This newest version of the remote switch was manufactured with a built-in spring permanently attached to the cell holder. Accordingly, proceed to section 10.4.

Figure 12: Spring configuration

10.3.2 Carefully remove the cell 131-0001 from the plastic cell holder and keep the conical spring.

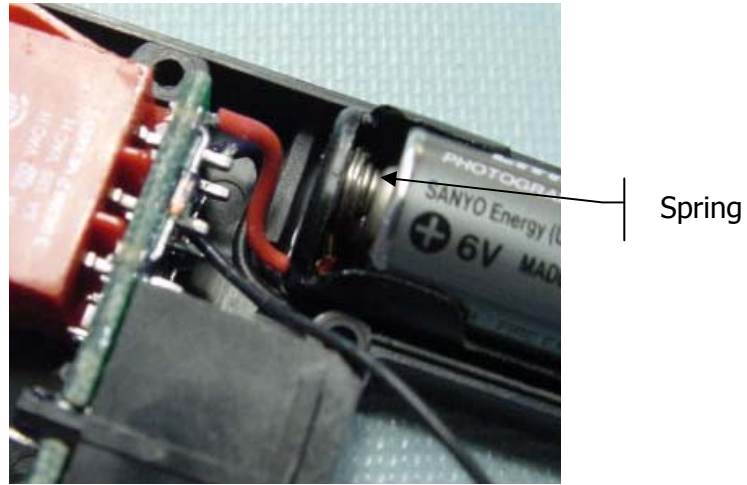

Figure 13: Conical spring

10.3.3 Dispose of the cell according to the instructions specified in section 10.6.

10.3.4 Carefully slide the replacement cell 131-0001 inside the plastic cell holder following the polarity mentioned inside the holder and on the cell, or by matching the positive (+) end of the cell to the red wire side of the holder.

10.3.5 Install the conical spring between the positive side of the cell and the cell holder.

10.3.6 Push the cell against the conical spring.

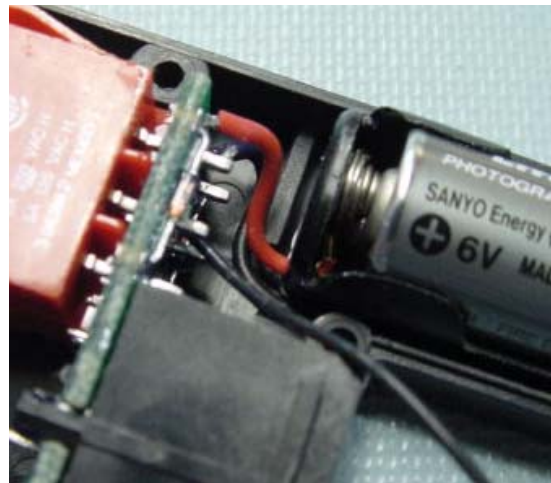

Figure 14: Conical spring installation

10.3.7 Gently route the black and red wires from the plastic cell holder away from the leads of the rocker switch if necessary.

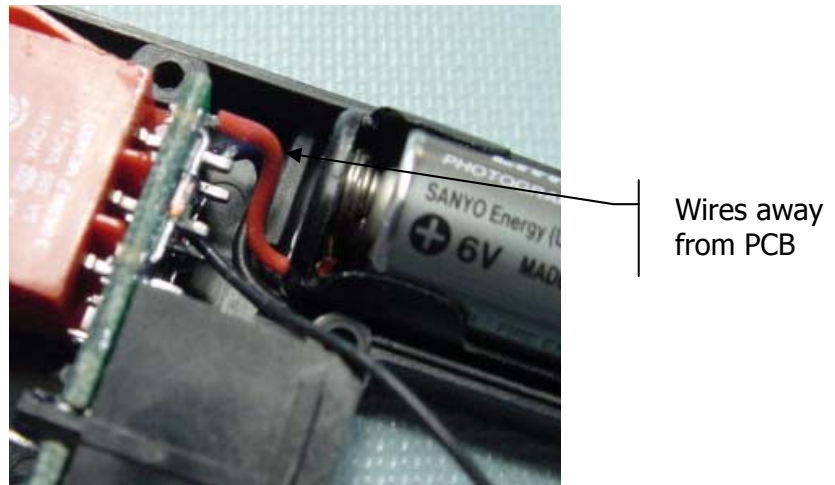

Figure 15: Cell holder wires

10.3.8 Position the ground wire (black) along the side of the plastic cell holder and away from the screw boss.

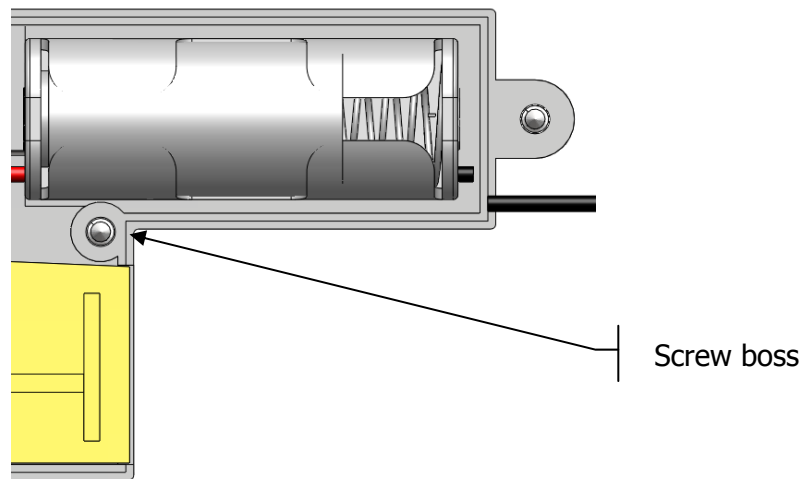
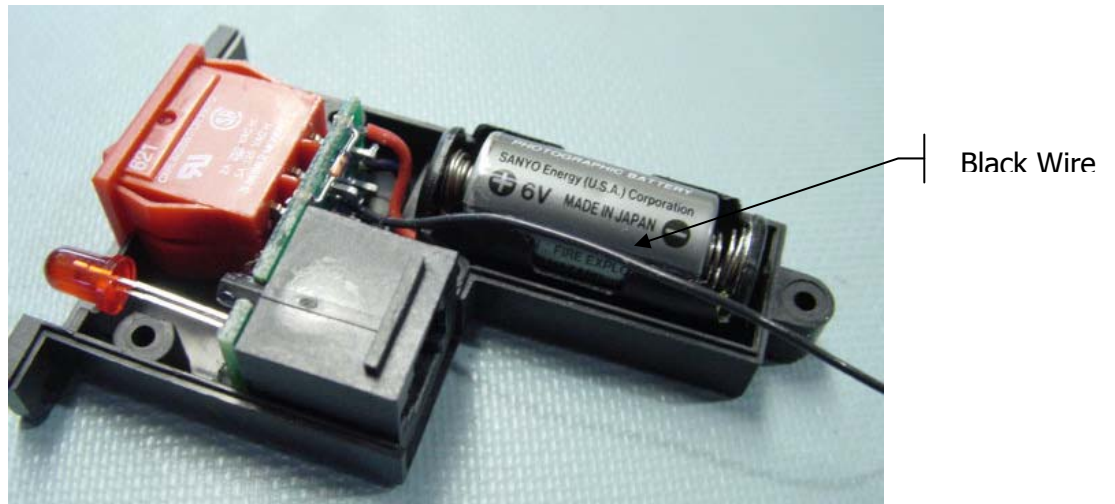

Figure 16: Ground wire

10.3.9 Refer to section 10.5 to install the mating cover.

10.4 Cell Replacement from Cell Holder with Built-in Spring

- 10.4.1 Carefully remove the cell 131-0001 from the plastic cell holder.
- 10.4.2 Dispose of the cell according to the instructions specified in section 10.6.
- 10.4.3 Carefully slide the negative end of the replacement cell 131-0001 inside the plastic cell holder following the polarity mentioned inside the holder and on the cell, or by matching the positive (+) end of the cell to the red wire side of the holder.

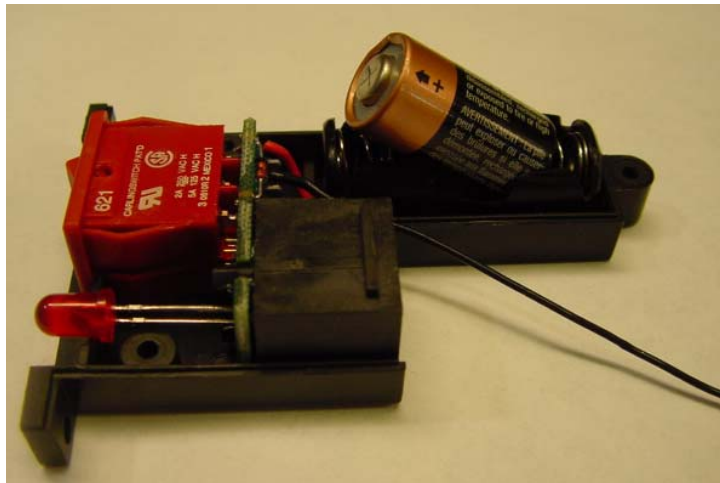

Figure 17: Cell installation

- 10.4.4 Pull the built-in spring away from the end of the cell using tweezers and slide the cell inside the holder.

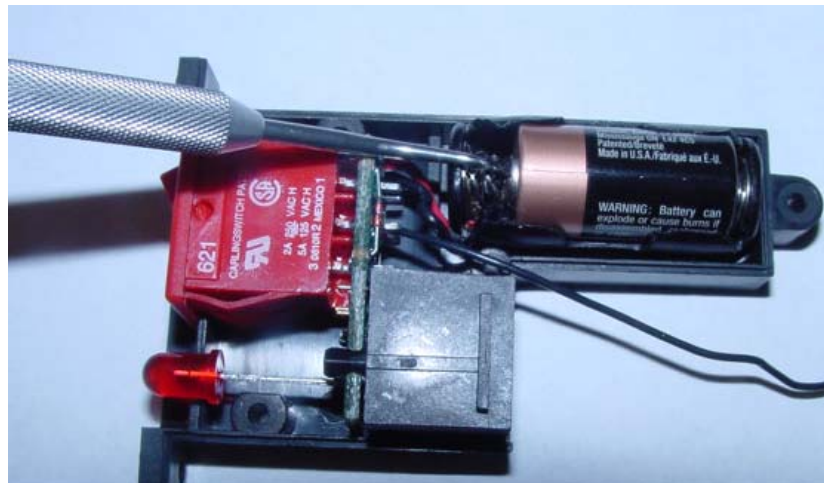

Figure 18: Spring installation

10.4.7 Position the ground wire (black) along the side of the plastic cell holder and away from the screw boss.

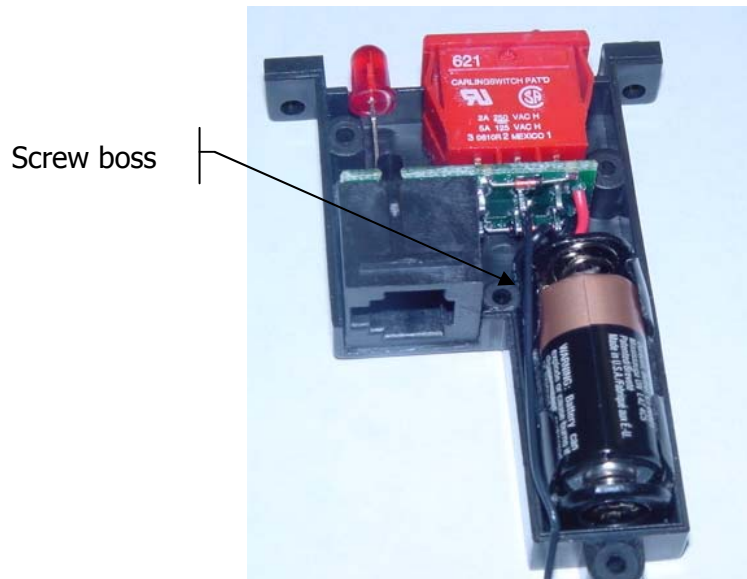
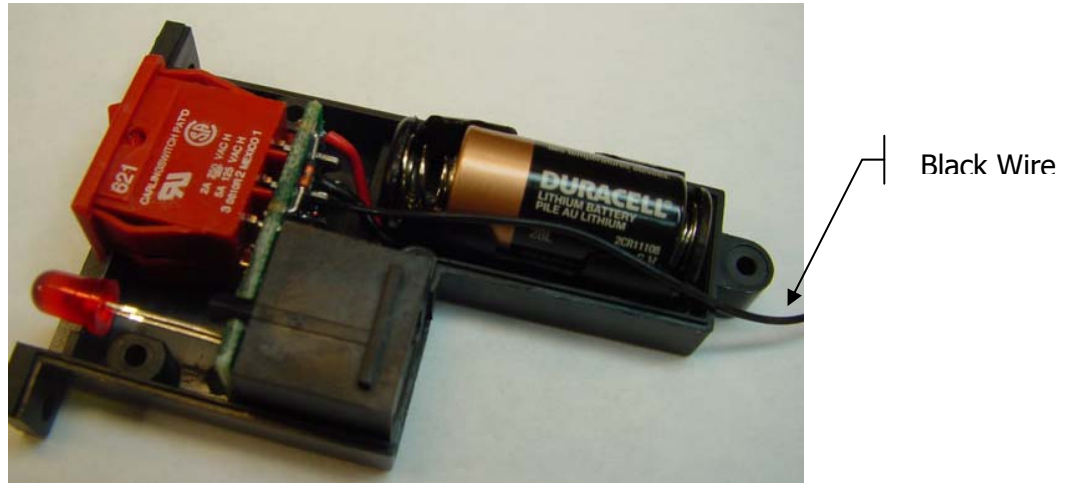

Figure 21: Ground wire

10.5 Mating Cover Installation

- 10.5.1 Install the mating cover to the assembly by matching the cutouts according to the different components.
- 10.5.2 Ensure that the 26 AWG ground wire is properly fed through the notch of the mating cover and is not pinched by the screw boss.

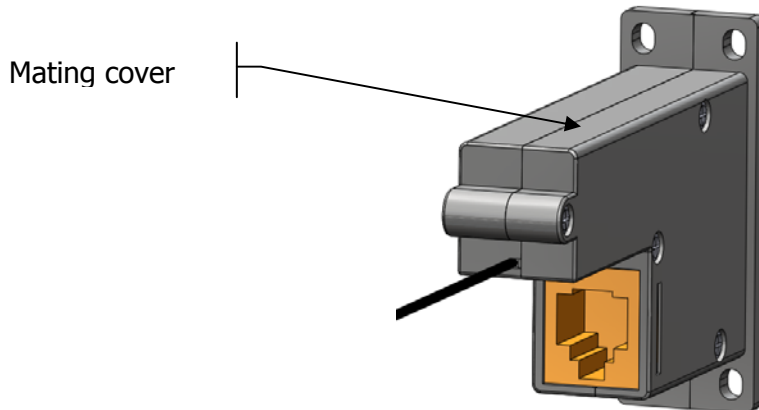

Figure 22: Mating cover installation

- 10.5.3 Secure the covers together using the retaining screws previously removed. The torque on the screws is 2.0 Lb-in (+0 Lb-in, - 0.5 Lb-in).

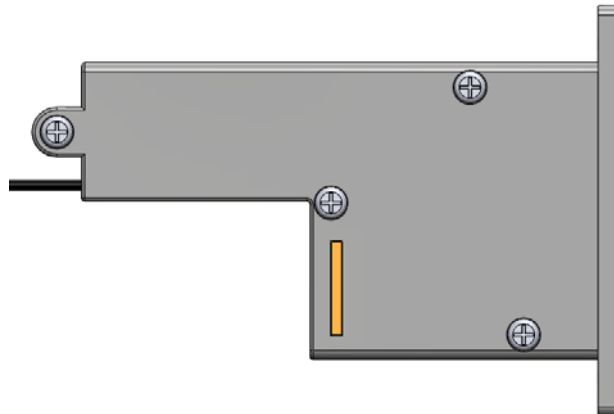

Figure 23: Retaining screws installation

- 10.5.4 Refer to section 7 to install the remote switch back on the panel.
- 10.5.5 Refer to the Transmitter Test section of the ME406 series ELT manuals to check the operation of the complete connection to the ELT.
- 10.5.6 Apply Cell Replacement Warning label 591-0036 from kit 455-0023 inside the aircraft's logbook. The intent of the label is to remind the pilot to change the cell inside the remote switch every five years or sooner depending on usage.
- 10.5.7 Enter the date, installer's initials and whether the ELT passed or failed into the aircraft's logbook.

10.6 Cell Disposal Instructions

Lithium batteries are best disposed of as a non-hazardous waste when fully or mostly discharged. The Federal Environmental Protection Agency (EPA) governed by the Resource Conservation and Recovery Act (RCRA) do not list or exempt Lithium as a hazardous waste. However, if waste lithium batteries are still fully charged or only partially discharged, they can be considered a reactive hazardous waste because of the significant amounts of un-reacted or unconsumed lithium remaining in the spent battery. The batteries must be neutralized through an approved secondary treatment facility prior to disposal as a hazardous waste (as required by the U.S. Land Ban Restrictions for the hazardous and Solid Waste Amendments of 1984.) Secondary treatment centers receive these batteries as manifested hazardous waste under code "D003 - reactive". Button cells are exempt because they contain so little lithium and therefore can be disposed of in the normal municipal waste stream.

11. TROUBLESHOOTING GUIDE

Refer to the ME406 series ELT manuals for flash error codes during Self Test.

SYMPTOM	LIKELY CAUSE	ACTION
LED of the remote switch is not flashing when either the ELT or the remote switch is turn ON.	The voltage of the cell is below 3.3 volts.	Replace the cell.
	The harness is not secured to the remote switch.	Check that the modular jack is fully inserted inside the back of the remote switch.
	The remote switch ground wire is not connected to the module interface ground.	For a metallic aircraft, check the resistance between the remote switch and the module interface (10 Ω min.)
	The module interface is not connected to the ELT.	Check the connection.
	Cell is not installed properly.	Check the polarity of the cell with respect to the plastic cell holder.
	The wiring configuration is incorrect.	Refer to section 5.

12. SPECIFICATIONS

12.1 Components Dimensions

The following dimensions are displayed in [millimeters] and inches.

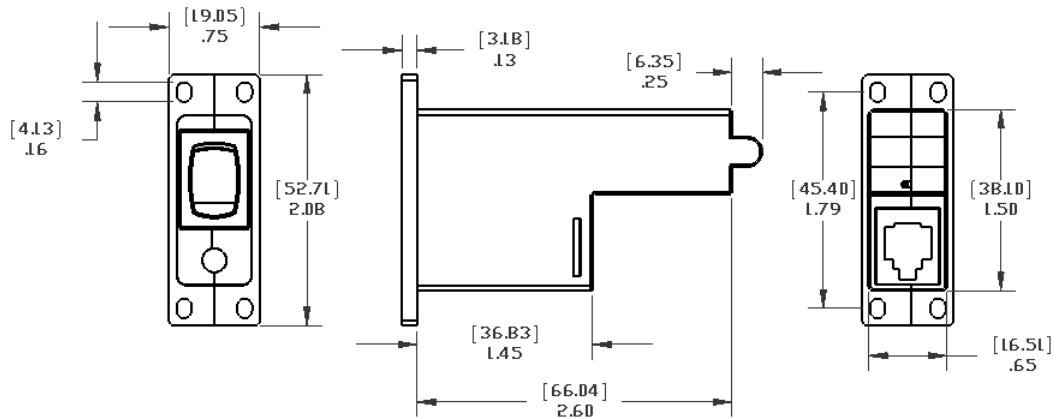

Figure 24: 453-0023 Remote Switch

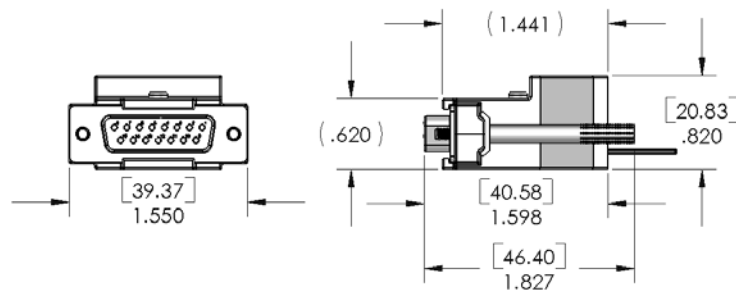

Figure 25: 453-1101 Module Interface

12.2 Components Weight

PART NUMBER	DESCRIPTION	WEIGHT
452-6505	Buzzer, Piezo	.34 oz (9.64 gr.) Max.
453-0023	Remote Switch, Self-Powered	1.30 oz (36.85 gr.) Max.
453-1101	Module Interface, ELT to Remote Switch	1 oz (28.35 gr.) Max.

The buzzer 452-6505 is included with the ELT Pack List.

13. INDEX

4

455-0023 Pack List, 8
455-7420 Pack List, 8

5

591-0003 Label, 16
591-3029 Label, 16

6

611-0018 Extender, 13
611-0019 Cable, 14

A

ACK retrofit, 14
Advisory Circular 43.13-2A, 10
Ameri-King retrofit, 13

B

Buzzer 452-6505, 11

C

Cell Disposal Instructions, 30
Cell Shelf Life, 21
Cell Warning, 21

D

Dimensions, Components, 31

E

Environmental Categories, 32

G

Ground Wire, Remote Switch, 19

H

Harness, 10

I

Installation, Module Interface, 20, 21
Installation, Remote Switch, 13

L

Label 591-0003, 16
Label 591-0036, 19, 29
Label 591-3029, 16
LED, 18, 30
List of Figures, 7

M

Module Interface Installation, 20, 21

O

Orientation, Remote Switch, 18, 19

P

Panel Cutout Dimensions, 16
Panel Cutout Instructions, 16
Parts List, 8

R

Remote Switch Installation, 13
Replacement, Cell Remote Switch, 21

S

Shelf Life, Cell, 21
Specifications, 31

T

Telephone Line, 10
Troubleshooting Guide, 30

W

Weight, Components, 31
Wiring Diagram for shielded cable (Composite Aircraft), 11
Wiring Diagram for telephone line (Composite Aircraft), 11
Wiring Diagram for telephone line (Metallic Aircraft), 12