

NOTES:

- * In Development
- ** Planned future Product
- *** Special

REVISIONS				
ECO	REV	DESCRIPTION	DATE	APPROVED
E0536X2	X1	INITIAL RELEASE	05/11/06	
E0536X3	X2	ADD X7 & X8 FREQ OPTIONS	08/24/06TG	
E0766	X3	ADD CG FREQ BAND, 3.1 – 3.4 GHZ	05/14/07TG	
E1228	X4	ADD FIRMWARE OPTIONS	09/10/09	
E1415	X5	REMOVE FW OPTIONS	04/06/10	

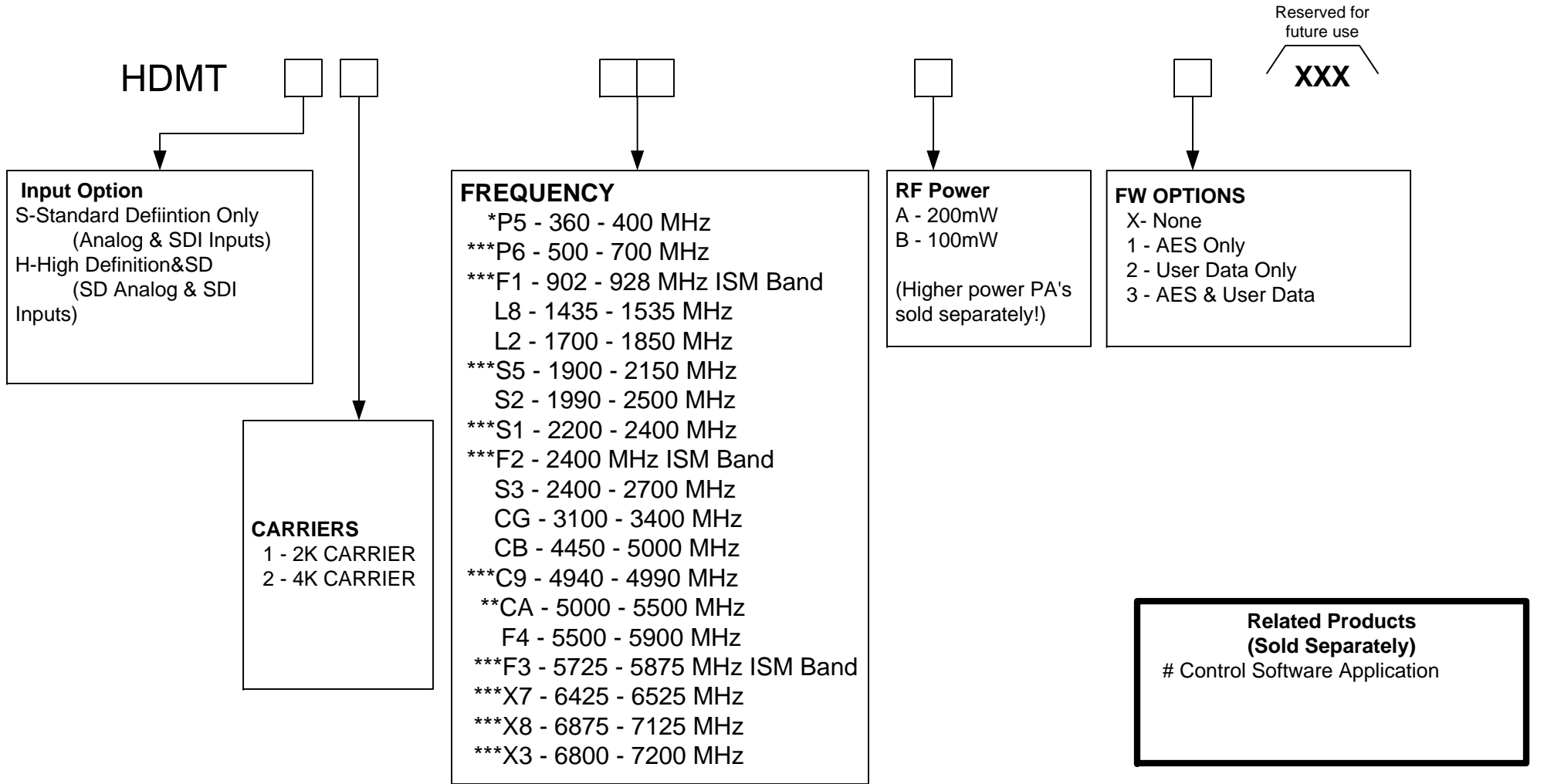

ENG/TECH	COBHAM GMS Products		DWG TITLE	
DRAWN			MNI, HDMT	
ENG	SIZE	DATE	DWG NO	REV
PROD	A	05/14/07	100-MNI0045X5	X5
QC	SCALE:	NONE	SHEET	1 OF 1